



INSTALLATION INSTRUCTIONS

Accessory

DOOR VISOR
P/N 08R04-SJC-100

Application

2014 RIDGELINE

Publications No.

All 50336

Issue Date

AUG 2013

PARTS LIST

Door visor (front left)

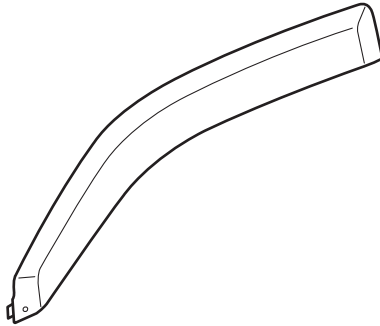

Door visor (front right)

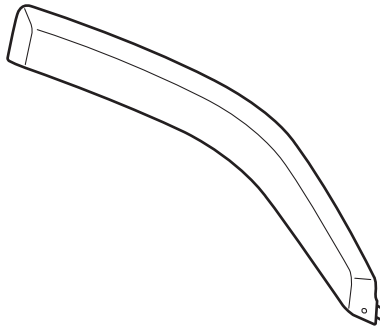

Door visor (rear left)

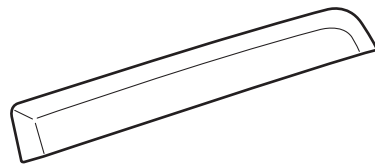

Door visor (rear right)

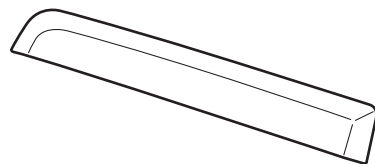

2 EPT sealers



SUPPLIES REQUIRED

- Isopropyl alcohol
- Shop towel
- Masking tape
- Tape measure

INSTALLATION

Customer Information: The information in this installation instruction is intended for use only by skilled technicians who have the proper tools, equipment, and training to correctly and safely add equipment to your vehicle. These procedures should not be attempted by "do-it-yourselfers."

NOTE:

- These instructions show the left door visors being installed; use the same procedure to install the right door visors.
- Be careful not to damage the paint finish and the glass run channels when installing the door visors.
- Handle the door visors with care. They are not designed to absorb shock or impact.
- This door visor kit should be installed only if the ambient air temperature is above 60°F (15°C).
- To allow the adhesive to cure, do not wash the vehicle for 24 hours.

Installing the Front Door Visor

1. Lower the front door glass completely. Remove the door glass run channel from the door sash in the area shown. Do not remove the glass run channel from the door mirror base.

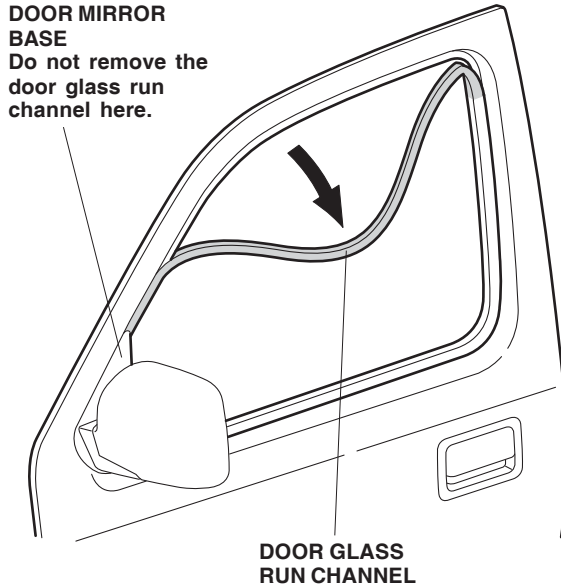

2. Using isopropyl alcohol on a shop towel, clean the shaded area of the door sash.

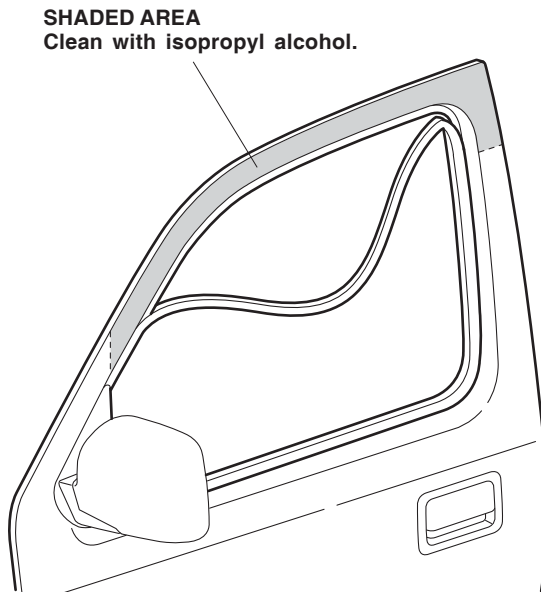

3. Locate the door sash in the area where the EPT sealer will attach. Using isopropyl alcohol on a shop towel, thoroughly clean the area.

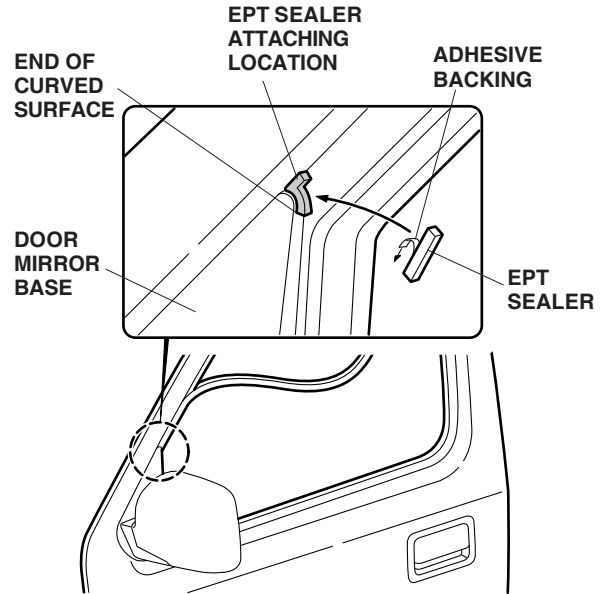

4. Trial fit the door visor to the door, and note the position that the EPT sealer needs to be installed in to seal and prevent wind noise. Remove the door visor. Remove the adhesive backing from the EPT sealer and attach it to the door mirror base as shown.

- Attach masking tape to the ends of the long adhesive backings, and remove 2 to 3 in. (5 to 8 cm) from the ends. Fold back the ends and tape the ends to the front of the door visor. Note the direction of the adhesive backings. Remove the short adhesive backing.

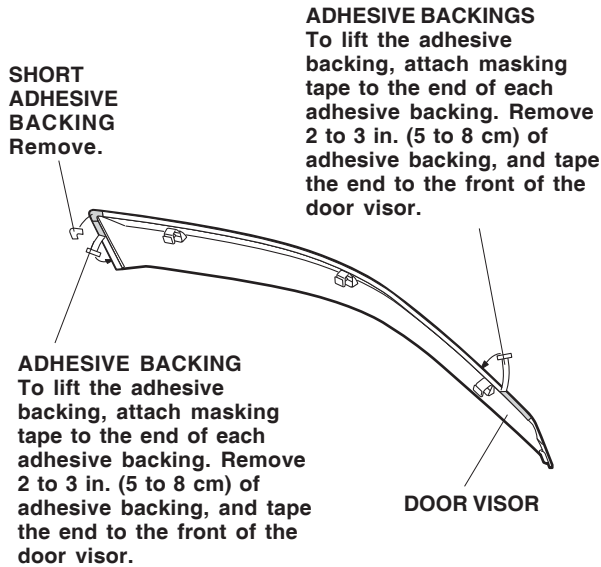

- Push the three door visor brackets onto the door sash and insert the front tab under the door mirror base.

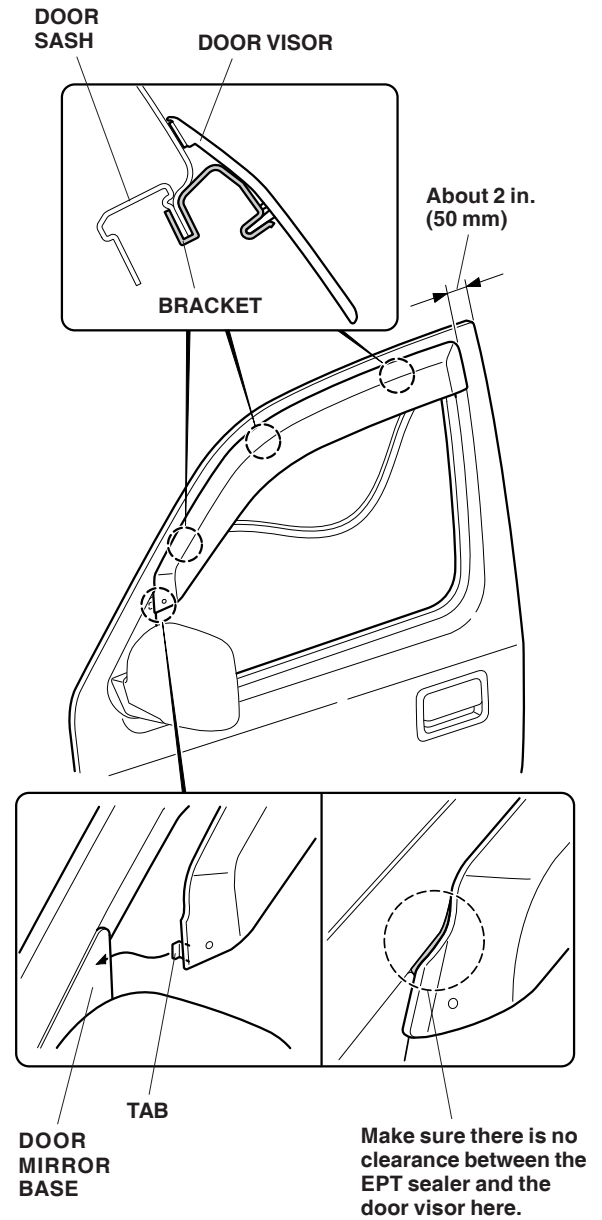

- Check that the distance between the rear end of the door visor and front door is about 2 in. (50 mm).

- While holding light pressure on the door visor, carefully remove the adhesive backing in the directions shown. Using the palm of your hand, hold the door visor firmly against the door for 30 seconds.

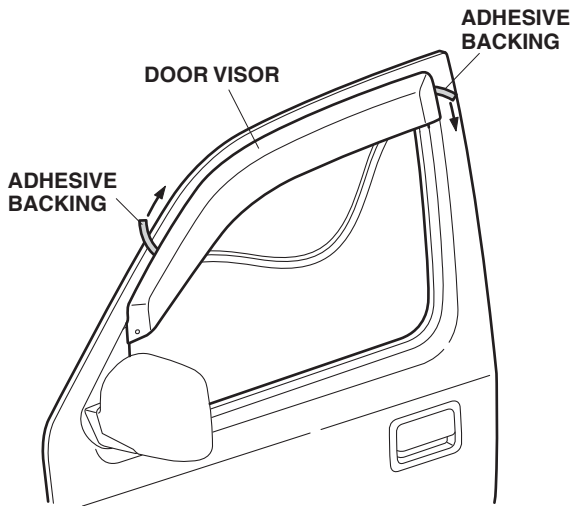

- Reinstall the door glass run channel. Seat the glass run channel properly around the three brackets.

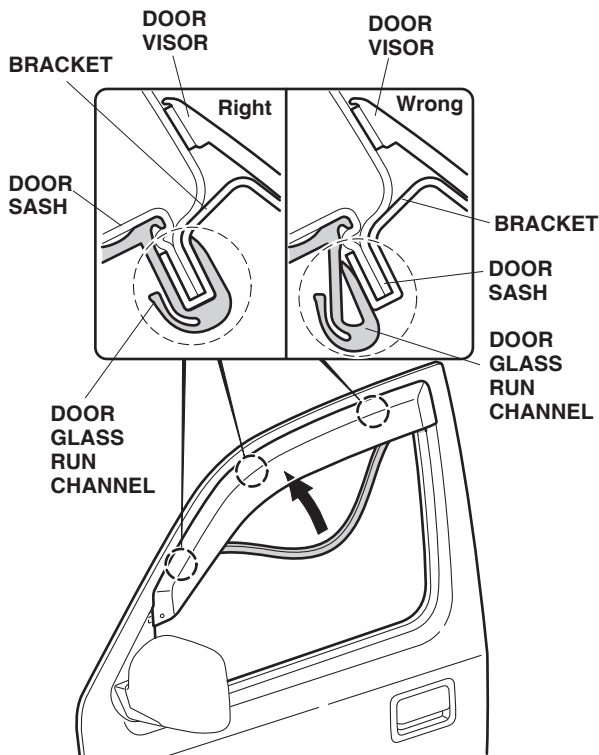

Installing the Rear Door Visor

- Lower the rear door glass completely. Remove the door glass run channel from the door sash in the area shown.

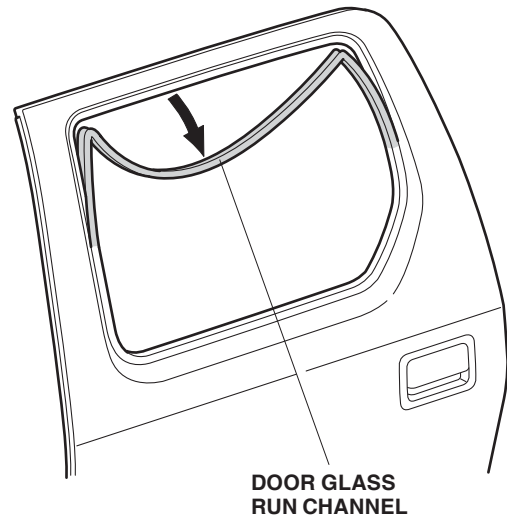

- Using a tape measure and a felt-tip pen, measure and mark the front of the rear door. Apply masking tape at the mark.

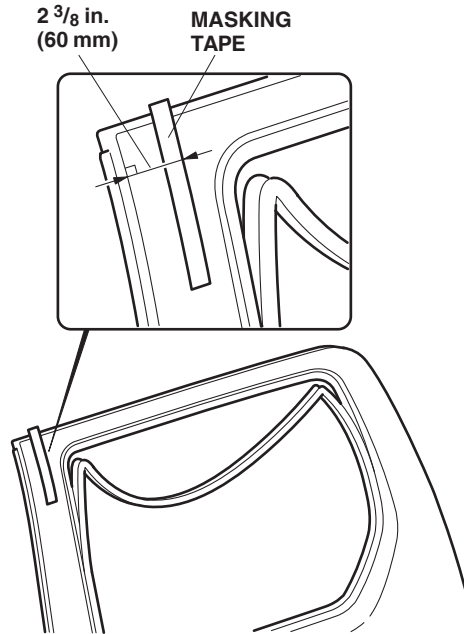

12. Using isopropyl alcohol on a shop towel, clean the shaded area of the door sash.

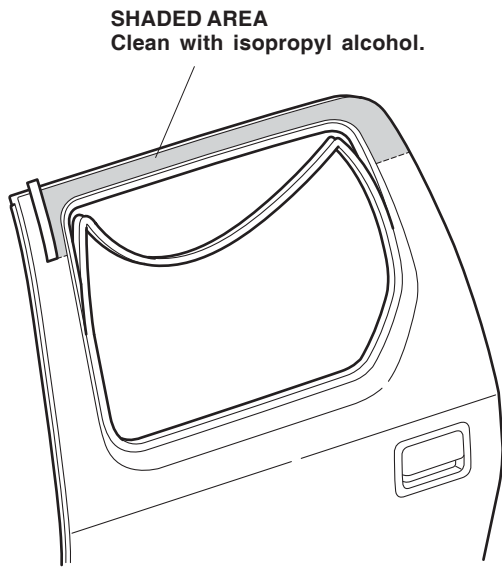

13. Attach masking tape to the ends of the long adhesive backings, and remove 2 to 3 in. (5 to 8 cm) of adhesive backings. Fold back the ends, and tape the ends to the front of the door visor. Remove the short adhesive backing.

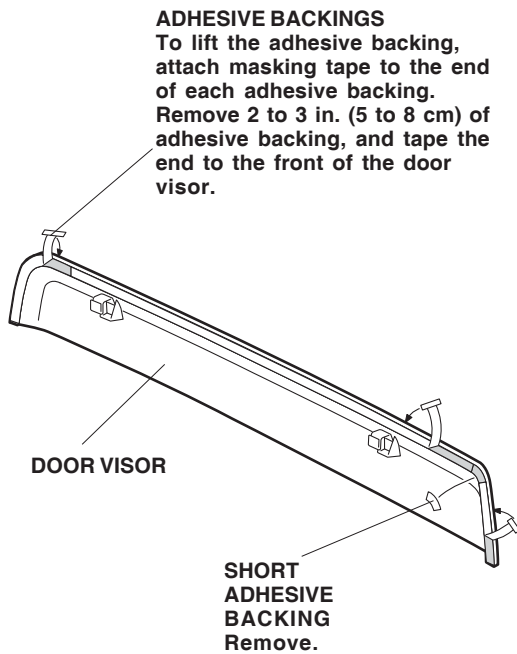

14. Push the two door visor brackets onto the door sash.

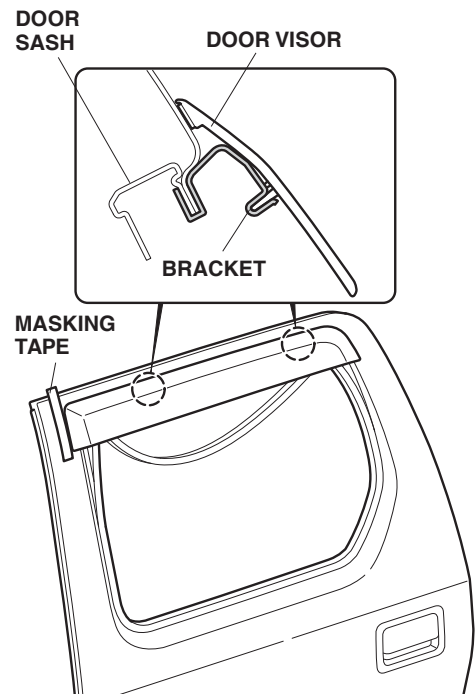

15. Align the front end of the door visor with the masking tape. While holding light pressure on the door visor, carefully remove the adhesive backing in the directions shown. Using the palm of your hand, hold the door visor firmly against the door for 30 seconds.

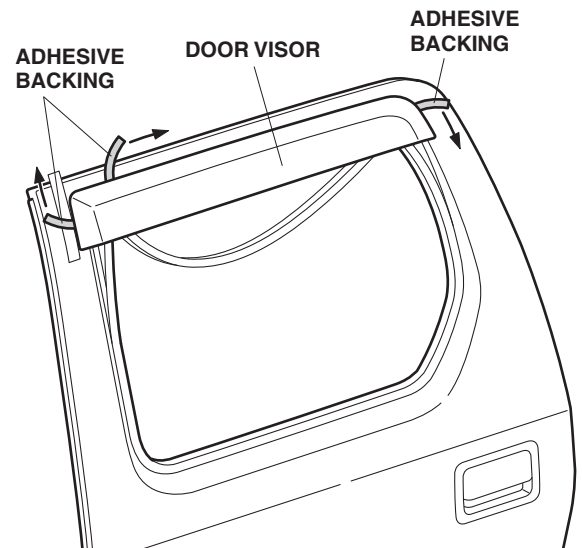

16. Reinstall the door glass run channel. Seat the glass run channel properly around the two brackets.

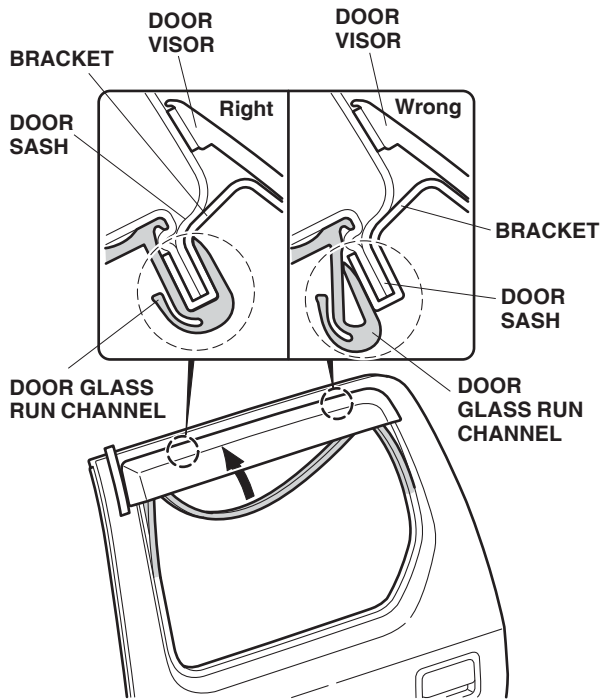

17. Repeat steps 1 through 16 to install the door visors on the right side of the vehicle.
18. Raise and lower all the windows several times to seat the glass run channels.

USE AND CARE

- To clean the door visor, wipe it with a soft cloth dampened with clean water.
- To remove dust and dirt, clean with a solution of liquid dishwashing soap and water using a soft cloth or chamois. Never use organic solvents such as thinner, benzene, alcohol, or cleaners containing compounds.